



instALERT

The instALERT® variable message sign is the ultimate in message sign portability. The ability to be folded and packed into any standard sized car boot means the instALERT® can be effortlessly transported from site to site. Sign deployment can quickly and easily be done within minutes by a single person who can then simply select or create a message to suit the situation.

Using the wireless Bluetooth PDA (included in starter kit) a user can edit, save and create messages to suit the situation instantly without even leaving the safety of their vehicle.

- 
Ultimate level of portability
- 
Deployed by one person within minutes
- 
Easily customise messages instantly on site
- 
Available with lockable hitch mount
- 
Up to 3 sequenced screen displays per message
- 
3 text sizes for appropriate viewing speed and distance
- 
Store up to 25 messages on sign
- 
Create, edit, save and store messages with PDA supplied in kit
- 
Programming via wireless Bluetooth technology with PDA or PC
- 
Compact for easy storage in car boot or truck locker
- 
Manual of Uniform Traffic Control Devices compliant
- 
Dual voltage 12V to 24V operation



instALERT Specifications

Voltage:	10-30V
Current Draw	Maximum of 6 Amps @ 12V
Screen displays per message:	up to 3 sequentially
Text Size 1:	4 characters @ 24"
Text Size 2:	8 characters @ 10"
Text Size 3:	12 characters @ 7"
Power lead length:	4.5m
Power lead type:	Cigarette Plug
Full-size, full-matrix display:	26 x 96 pixels
Weight:	19.5kg
Carrying Size:	76.2mm x 711.2 mm x 762mm
Unfolded Size:	712mm x 1,532mm
Operating Temp.	-29°c to + 71°c
Message storage on sign:	25
Message storage on PDA:	Unlimited
Road Speed Rating	Towbar hitch mount 10kph
Wind Rating	Portable stand 110kph
Viewing Distance	Text size dependant 350m +
Body:	Powder coated aluminium
Screen:	Lexan

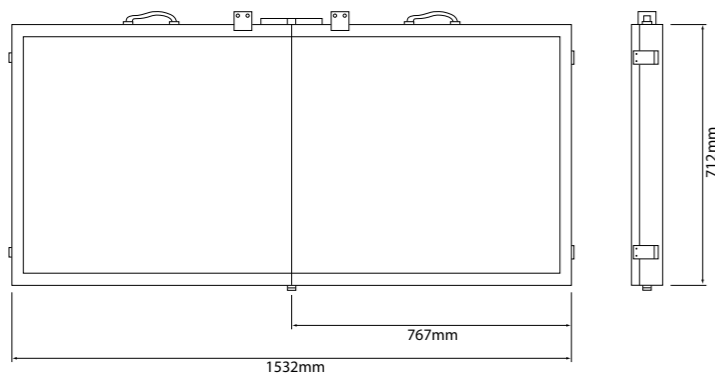

instALERT Variable Message Sign		
Part No.	Description	Figure
4000363	Message Board Starter Kit Kit contains: Fold up variable message board & bag, hitch mount, mounting plate, PDA & software	-
Part No.	Description	Figure
4000159	Fold-up variable message board & bag	1
4000181	Mounting plate for message board	2
4000247	Towbar hitch mount & lock for message board (requires mounting plate)	3
4000250	PDA & software	4
4000263	Portable stand for message board (requires mounting plate) <i>Not part of starter kit</i>	5

instALERT Software - PC & PDA Versions

Comes with over 100 default messages

Draw your own graphics using a PC

Comprehensive PC & PDA software

Instant wireless message board control

Design your own message with simple controls

Manage stored messages at the touch of a screen