

## Low Intensity Strobes



Part No. 6220A-2



Part No. 6400A-1

Vision Alert offers a budget range of strobe safety beacons designed for the fork lift industry.

Available in high and low profile this range is recommended for use in light duty applications and have an operating voltage of 12-80 volts DC.

The high profile model features an epoxy filled base providing excellent protection against vibration, dust and moisture.

Strobe Lights		
Part No.	Description	Fig
<b>6220A-2</b>	12-80VDC Potted high profile strobe	1
<b>6400A-1</b>	12-80VDC Low profile strobe	2
<b>6220-2TUBE</b>	Spare tube for 6220A-2	-

 <p>Fig 1</p>	 <p>Fig 2</p>
--	--

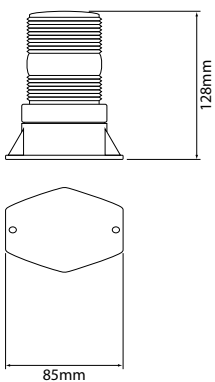
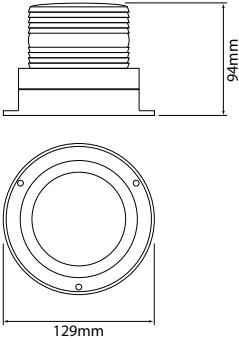